

## **RESIDENTIAL DETACHED GARAGES** **BUILDING PERMIT REQUIREMENTS**

This guideline is intended to provide the homeowner/contractor with the basic information needed to apply for a building permit to construct a detached garage.

1. Fill out and sign application for a building permit.
2. Submit four (4) separate copies of your plot (site) plan drawn to scale showing existing structures and the proposed detached garage and its perpendicular distances to the lot lines and from the other structures on the lot, if any.  
Site plans must show water run-off (use arrows to indicate flow of water). The location of the detached garage can not obstruct any swales or natural water run-off.
3. Obtain zoning approval from the St. Louis County Department of Public Works (if unincorporated) or from municipality. In municipalities site plans must be marked "Approved" and Municipal Approval Form submitted prior to permit issuance..
4. Submit four (4) separate complete sets of detailed building construction plans drawn to scale containing the following:

Foundation and Floor Plan @ 1/4" = 1'-0"  
Elevations @ 1/4" = 1'-0"  
Sections and Details @ min. 3/4" = 1'-0"

Include one of the following in your plan submittal depending on choice of roof framing systems:

- (1) If by conventional method, indicate size and spacing of rafters, ceiling joists, and/or ties on the sections and details included in the plans submitted.
  - (2) If by the "truss" method, submit four (4) copies of the engineer's sealed truss plan which can be obtained from the lumber dealer or the "truss" fabricator. Trusses comply with AFPA NDS-01 and TPI 1-02.
5. All electrical work (if proposed) must be performed in accordance with St. Louis County Codes and Ordinances by a licensed electrical contractor or a pre-authorized homeowner who by examination has demonstrated the necessary knowledge and ability to perform the work.
  6. Issuance of a building permit for the project does not authorize construction access to the work site. If the existing driveway entrance to the site is unavailable for construction access, the owner/contractor shall apply for a permit to construct a temporary entrance from the owner of the Right-of-Way.

For additional information regarding the criteria in this handout, please contact:

	<u>Contact</u>
General Information	(314) 615-5184
Permit Processing	(314) 615-7155
Zoning Review	(314) 615-3763
Building Plan Review	(314) 615-5485
Right-of-Way Owner	
State	(888) 275-6636
County	(314) 615-8517
Municipality	Municipality

Refer to the attached drawings and the following listing of common code requirements pertaining to most detached garages for additional information that needs to be included on the building construction plans.

### **Footing and Foundation Walls**

The footing shall be a minimum 6" thick x 12" wide installed 30" below grade. The foundation wall on top of the footing shall be a minimum of 8" in thickness and extend a minimum of 8" above the outside grade.

Exception: The foundation wall may terminate 6" above the outside grade if all wood on top of the foundation wall located less than 8" above the outside grade is pressure treated.

The foundation wall and footing may be a single pour if the wall is flared at the bottom a minimum of 12" in width.

Detached garages 400 square feet or less in area (using the exterior dimensions of the garage) and a roof eave height of 10' or less may be constructed on the top of a perimeter concrete slab turndown 8" in thickness and a minimum of 12" below grade.

### **Sill Plate Anchorage**

1/2" diameter anchor bolts, 7" minimum embedment, 6' maximum o.c. spacing and at ends/corners with 1-1/2" diameter washers and nuts. Minimum 2 bolts per plate regardless of length.

### **Exterior Wall Framing**

2 x 4 or 2 x 6 framing standard grade or better studs may be spaced 24" o.c. in a wall 10' or less in height.

### **Roof Framing**

For conventional framed roof systems, indicate size, spacing, fiber stress, type and grade of wood for roof rafters and ceiling joists. Indicate roof pitch. Show rafter and ceiling joist framing layout on plans.

Trussed roofs and/or floors shall have sealed truss plans indicating spacing and roof pitch for each span utilized. Include girder trusses if utilized. Show truss framing layout including girder locations on the plans. All trusses shall comply with TPI 1 -2002.

All roof framing shall be designed to support the following minimums:

Top chord of trusses or roof rafter:	Snow Load 20 lb. per sq. ft. Dead Load Use actual dead load.(Note: Dead load must include 2 layers of roofing membrane
Ceiling joists or Bottom chord of trusses:	Use a live load of 20 lb. per sq. ft when there is attic storage. Use 10 lb per sq. ft. live load where there is no attic storage. Dead load— use actual dead load.

Note: The live load design on the ceiling joist or bottom chord of a truss shall not be required if all of the following conditions are adhered to:

- a. Attics with drywall ceilings below that are accessed only by a 22" x 30" scuttle opening without a pull-down stairway.
- b. Warning signs attached to the trusses on each side of the scuttle opening at least 36" above the bottom chord and within 18" of the edge of the opening. The signs shall be constructed of metal or other approved durable materials suitable for the location and be a minimum of 40 sq. inches in area with 3/4" minimum high letters on a contrasting background that reads "WARNING-TRUSSES NOT DESIGNED FOR ATTIC STORAGE".
- c. Attic areas over garage areas with drywall ceilings shall also be provided with a horizontal railing attached to the trusses on each side of the scuttle opening at least 24" and not more than 36" above the bottom chord. The railing is intended to be an obstruction to easy access for storage and shall be constructed of either 1x4's, 2x4's or 3/8"x 6" plywood. It may be shop or field applied.

Where trusses or rafters are spaced 24" o.c., roof panels shall be a minimum of 15/32" thick sheathing without edge support or a minimum of 3/8" thick (minimum 24/0 span rated) sheathing with edge support. Edge support shall be tongue-and-groove edges, panel edge clips (at mid-point between each support) or 2x lumber blocking.

### **Roof Sheathing**

Roof sheathing: Where trusses or rafters are spaced 24" o.c. roof panel sheathing shall be a minimum of 7/16" thick without edge support or 3/8" thick with edge support. Edge support shall be tongue-and-groove edges, panel edge clips (at mid-point between each support) or 2X lumber blocking. Nailing shall be 6d common for 3/8" and 1/2" sheathing and 8d common for sheathing greater than 1/2" (location - 6" o.c. along edges, 12" o.c. intermediate).

### **Wall Bracing**

All walls shall be braced using the attached "Garage Bracing Guideline for One and Two Family Dwellings or Townhouses" or you may brace the garage using the following document found at [www.stlouisco.com/pubworks](http://www.stlouisco.com/pubworks):

- Appendix A, One and Two Family Wind Bracing Guideline.

### **Garage Floor Slab**

Minimum thickness of concrete floor slabs supported directly on the ground is 3 1/2". The

slab shall be placed over a minimum 4" base course of gravel or crushed stone.

### **Roofing Underlayment and Covering**

Class A, B, or C roofing shall be required where the edge of the roof is less than 3' to the property line.

Underlayment for asphalt shingles:

Slopes of 2:12 to less than 4:12 shall be protected with two layers of underlayment. Apply a 19" strip of underlayment felt parallel with and starting at the eaves, fastened sufficiently to hold into place. Starting at the eave, apply 36" wide sheets of underlayment. Successive 36" wide sheets of underlayment shall overlap the previous 36" wide sheet by 19". All underlayment shall be fastened sufficiently to hold into place.

Slopes equaling or exceeding 4:12 shall be protected with one layer of underlayment. Underlayment shall be applied shingle fashion, parallel to and starting from the eave and lapped 2", fastened sufficiently to hold in place. End laps shall be offset by 6'.

All underlayment to be a minimum of Type I per ASTM D226-97a or Type I per ASTM D4869-88(1993)e (Type I is commonly called No. 15 asphalt felt.)

Indicate corrosion-resistant flashing at all wall and roof intersections, changes in roof slope or direction, around all roof openings, intersections with chimneys, intersection of exterior walls and porches and decks, etc. Valley flashing shall be installed per R905.2.8.2

Built-up membrane roof slope is 1/4:12 with approved low-slope roof covering materials. A Coal-Tar built-up membrane may be installed on 1/8:12 slope.

Mineral-surfaced roll roofing shall conform to ASTM D 224, D 249, D 371, D 3909. It shall not be installed on roof slopes below 1:12.

### **Siding**

Owners choice of finish weather-resistant siding.

### **Electrical**

Receptacles (when proposed) must be on ground fault circuit.

The preceding requirements apply to most detached garages, however, the Plan Reviewer may determine that unusual circumstance dictate the need for additional information on any particular project.

For structures proposed 3' or closer to a property line consult both Zoning (unincorporated area) and Building Plan Review within the Department of Public Works.

## GARAGE BRACING GUIDELINE FOR ONE AND TWO FAMILY DWELLINGS OR TOWNHOUSES

The plans for a garage do not have to identify the brace wall line locations and identify the percentage of braced wall panels with respect to a braced wall line if all of the following criteria are met:

1. The building addition exterior walls are sheathed with 7/16" or thicker wood structural panels (plywood or OSB). The wood structural panels shall be applied to all new exterior walls, gable ends, and band boards. All vertical joints between panels shall be blocked. Horizontal joints between panels on detached garage may remain unblocked.
2. Braced wall panels are located in every exterior braced wall line in accordance with the following criteria:
  - a. The edge of the first braced wall panel meeting the width established in the table below is located 12'-6" or less from each end of the braced wall line.  
Exception: The edge of the first braced wall panel may be located more than 12'-6" and up to 20'-0" from the end of the braced wall line if the collector system "Panel Offset" criteria on p.9 of Appendix A, One and Two Family Wind Bracing Guidelines is adhered to and detailed on the construction documents or when an Engineer or Architect provides calculations and details for an alternate collector system.
  - b. The centerline spacing of braced wall panels in a braced wall line may not exceed 25'.
3. Braced wall panel locations are shown on the floor plans or the elevation views and meet the widths established in the following table:

		WIDTH OF SOLID PANEL <sup>a, b</sup>			
		8' wall height	9' wall height	10' wall height	12' wall height
Plywood/OSB Panel	3:1	32"	36"	40"	48"
APA Narrow Portal Wall <sup>c</sup>	6:1	16" <sup>d</sup>	18" <sup>d</sup>	20" <sup>d</sup>	24" <sup>d</sup>

<sup>a</sup>Linear interpolation is permitted

<sup>b</sup>Wall height is the vertical distance from the bottom of the sole/sill plate to the top of the double top plate. An additional 2" variation in height is allowed for pre cut stud framing.

<sup>c</sup>The APA Narrow-Wall Panel, if applicable, shall be constructed in accordance with Figure 3. The designer shall provide this detail on the construction documents.

<sup>d</sup>This APA Narrow Portal Wall width assumes the beam is placed under the top plate of the wall. One may compute the required width based on a 6:1 height to width ratio for a top of beam height located lower in the wall (i.e.: 20" Portal Wall can be used when the top of beam is at 10'-0" in a 12'-0" tall wall).

4. The exterior wall corners shall be constructed in accordance with Figures 1 and 2. The designer shall provide these details on the construction documents.
5. When the perpendicular distance between the exterior braced wall lines exceeds 50', an interior wall fully sheathed with 7/16" wood structural panels (plywood or OSB) must be provided or a Design Professional (Engineer or Architect registered in the State of Missouri) shall include the following certification on the drawings:  
The interior and exterior wall configuration braces the structure in accordance with or equivalent to the lateral bracing provisions of Section R602.10 of the 2003 edition of the IRC or Section 2305 of the 2003 edition of the IBC.
6. Wall height may not exceed 12' (12'-2" actual). Walls greater than 12' shall be designed and detailed by the Design Professional to resist wind loads in both the longitudinal and transverse directions.

**Figure 1**

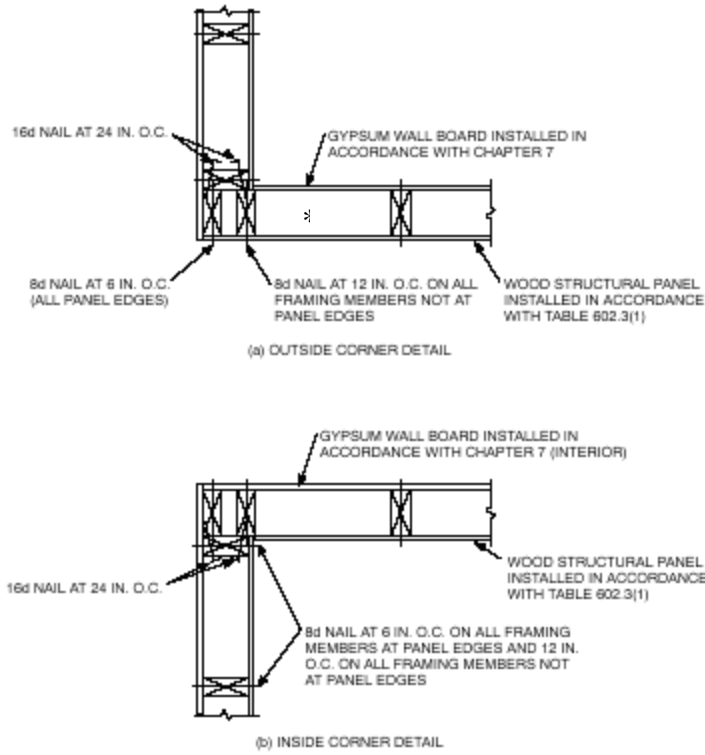

1/8" = 25.4 mm.

**Figure 2**

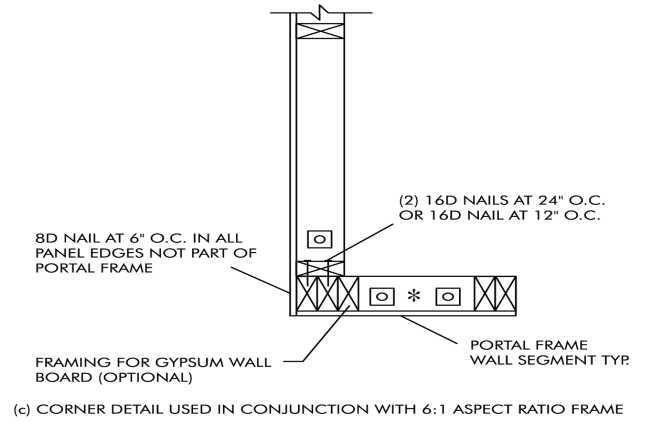

\*End stud on the above details may be shifted 7/16" to allow stud face to be aligned with sheathing.

**GARAGE BRACING GUIDELINES (continued)**

**Figure 3**

**CONSTRUCTION DETAILS FOR THE APA NARROW-WALL BRACING METHOD WITHOUT HOLD-DOWNS**

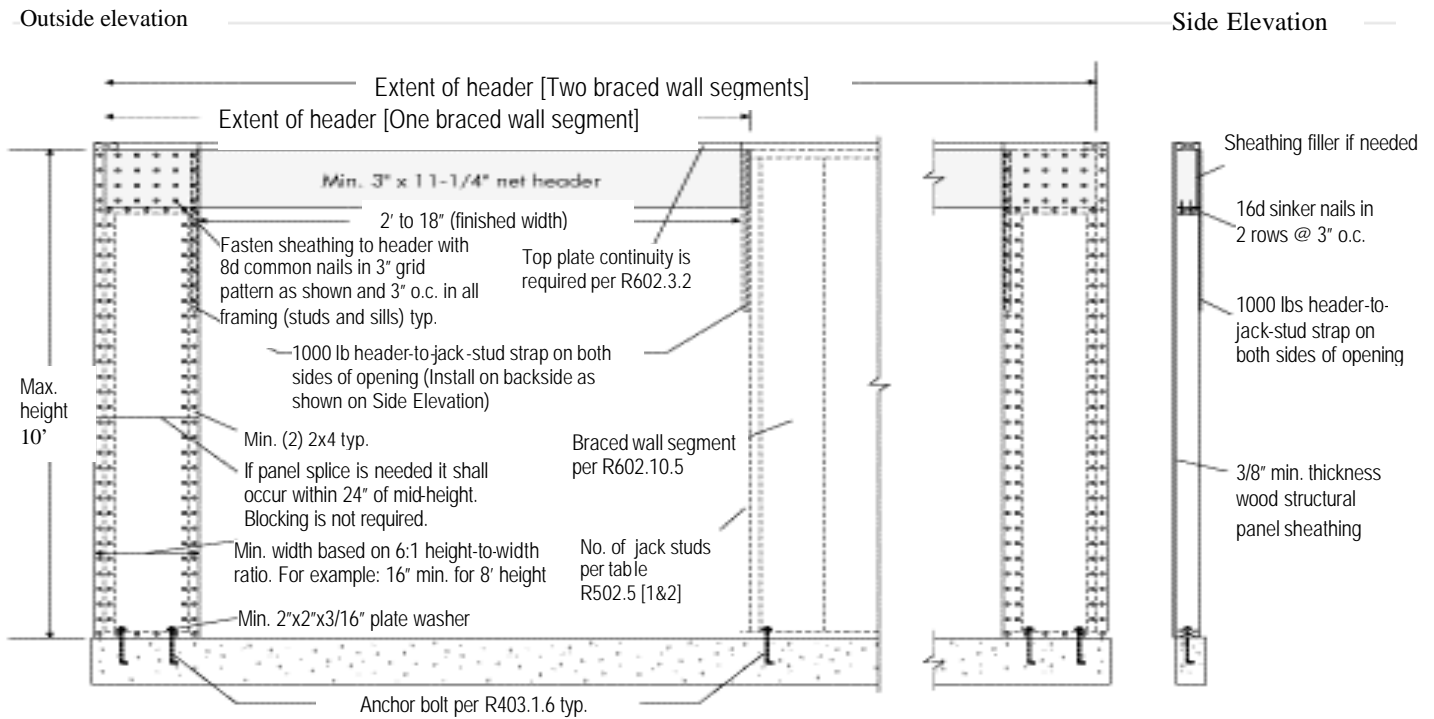

**Over concrete or masonry block foundation**

\*Cripple wall framing consisting of stud framing, single bottom plate, and double top plate may be added to the top of the APA Narrow Portal Wall as long as the combined height of the two walls is less than or equal to 12' and the two walls are strapped together on the interior side with a vertical 16 gauge metal 1 1/2" in wide by 21" long strap. A minimum of 10" of the strap shall be connected to each wall or gable truss with 9-16d nails for a total of 18-16d nails in the entire strap. Straps shall be located at each end of the connected walls or wall and gable truss where space allows for the 10" length of strap. The spacing between the straps may not exceed 4' on center. The straps shall not be bent horizontally to accommodate wood framing. If applicable, nailers should be added to one of the walls or gable end using a minimum of 9-16d nails to create the vertical plane needed to mount the strap.



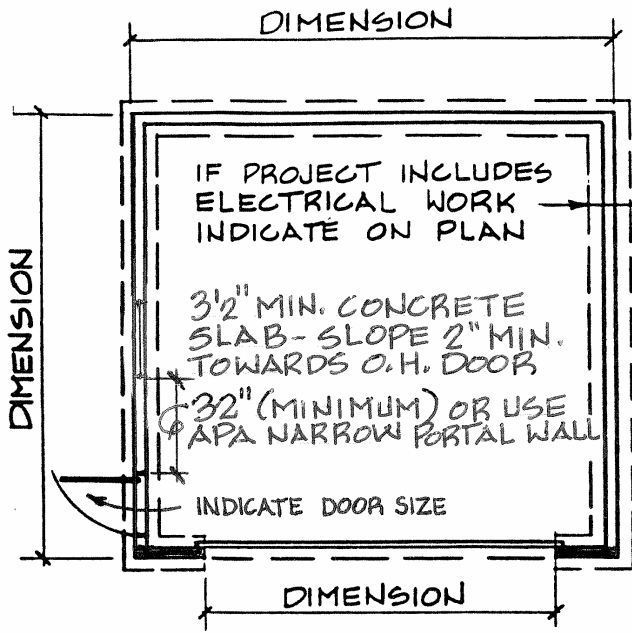

FOUNDATION & FLOOR PLAN  
SCALE: 1/4" = 1'-0"

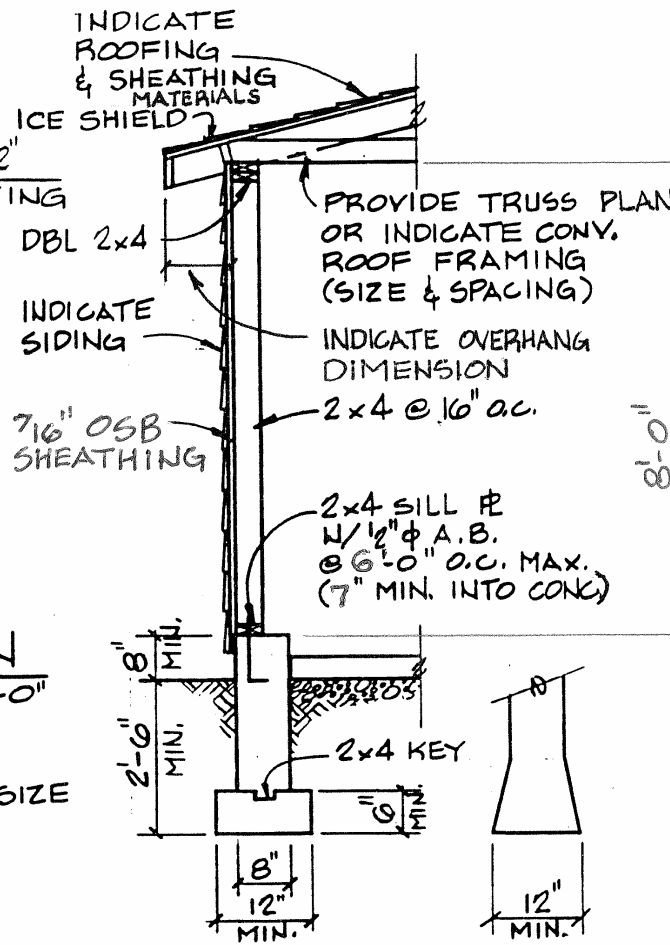

TYPICAL WALL SECTION  
SCALE: 3/4" = 1'-0"

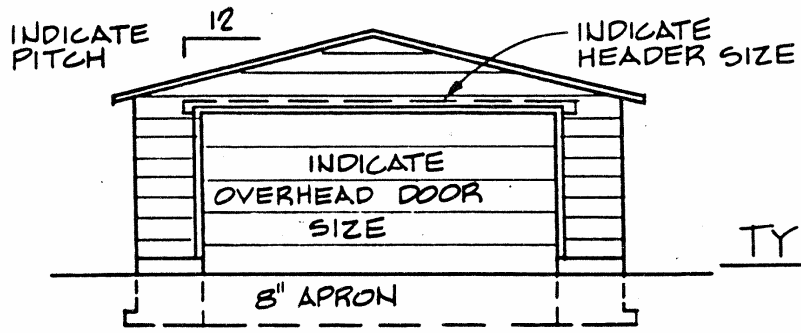

FRONT ELEVATION  
SCALE: 1/4" = 1'-0"

█ - INDICATES A 16" WIDE APA NARROW PORTAL BRACED WALL PANEL (INCLUDE DETAIL FROM HANDOUT) OR PROVIDE 32" WIDE OSB PANEL

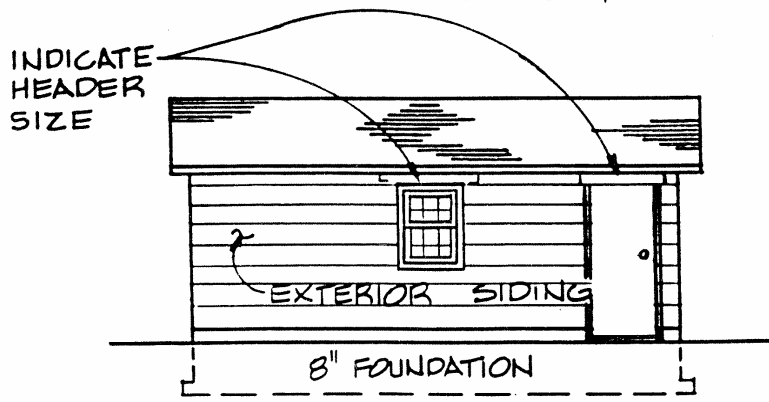

SIDE ELEVATION  
SCALE: 1/4" = 1'-0"

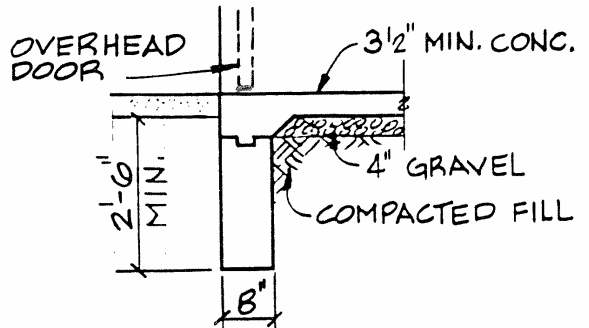

APRON DETAIL  
SCALE: 3/4" = 1'-0"